

When printed, this is an uncontrolled copy.

DICOM Conformance Statement

VISUCAM^{PRO NM} , VISUCAM^{NM FA}
and VISUCAM^{NM FA Opt AF}

Version 4.2.1

featuring Network Broker

Version 1.3.3

Carl Zeiss Meditec AG

Göschwitzer Strasse 51-52

07745 Jena

Germany

www.meditec.zeiss.com

1 Conformance Statement Overview

This document is structured as suggested in the DICOM Standard (PS 3.2, 2007).

SOP Classes	User of Service (SCU)	Provider of Service (SCP)
Transfer		
Ophthalmic Photography 8 Bit Image Storage	Yes	No
VL Photographic Image Storage	Yes	No
Workflow Management		
Modality Worklist Information Model - FIND	Yes	No

2 Table of Contents

VISUCAM NM – Network Broker.....	Fehler! Textmarke nicht definiert.
1 Conformance Statement Overview	2
2 Table of Contents.....	3
3 Introduction	4
3.1 Revision History.....	4
3.2 Audience.....	4
3.3 Remarks	4
3.4 Definitions, Terms and Abbreviations.....	4
3.5 References	4
4 Networking	5
4.1 Implementation Model.....	5
4.1.1 Application Data Flow	5
4.1.2 Functional Definition Of AEs	5
4.1.2.1 Functional Definition Of Network Broker.....	5
4.1.3 Sequencing of Real-World Activities.....	5
4.2 AE Specifications.....	7
4.2.1 Network Broker Application Entity Specification	7
4.2.1.1 SOP Classes	7
4.2.1.2 Associations Policies	7
4.2.1.2.1 General.....	7
4.2.1.2.2 Number of Associations.....	7
4.2.1.2.3 Asynchronous Nature.....	7
4.2.1.2.4 Implementation Identifying Information.....	7
4.2.1.3 Association Initiation Policy	7
4.2.1.3.1 Activity – Query Modality Worklist.....	7
4.2.1.3.2 Activity – Store images.....	10
4.2.1.4 Association Acceptance Policy	11
4.3 Network Interfaces.....	12
4.3.1 Physical Network Interface	12
4.3.2 Additional Protocols.....	12
4.4 Configuration	13
4.4.1 AE Title/Presentation Address Mapping	13
4.4.1.1 Local AE Titles	13
4.4.1.2 Remote AE Titles.....	13
4.4.2 Parameters	13
4.4.2.1 General Parameters.....	13
4.4.2.2 Modality Worklist SCU Parameters.....	13
4.4.2.3 Storage SCU Parameters.....	15
5 Media Interchange	16
6 Support of Character Sets.....	17
7 Security	18
8 Annexes	19
8.1 IOD Contents	19
8.1.1 Created SOP Instance(s).....	19
8.1.1.1 Ophthalmic Photography	19
8.1.1.2 Visible Light	29
8.1.2 Usage of Attributes from Received IOD's.....	36
8.1.3 Attribute Mapping	36
8.1.4 Coerced/Modified Files.....	36
8.2 Data Dictionary of Private Attributes.....	37
8.3 Coded Terminology and Templates.....	37
8.3.1 Private Code Definitions.....	37
8.4 Grayscale Image Consistency	37
8.5 Standard Extended / Specialized/ Private SOP Classes.....	37
8.6 Private Transfer Syntaxes	37

3 Introduction

3.1 Revision History

Document Version	Author	Date	NB Version
1.1 - 1.2	Jörg König	20.02.2006	1.1
1.3	Roberto Witt	06.02.2008	1.3.3
1.4	H.-Joachim Riedel	25.04.2008	1.3.3
1.5	H.-Joachim Riedel	23.06.2008	1.3.3

3.2 Audience

This document is intended for hospital staff, health system integrators, software designers or implementers. The reader should have a basic understanding of DICOM.

3.3 Remarks

If another device matches this conformance statement based on the comparison with its own conformance statement, there is a chance, but no guarantee, that they interoperate. DICOM only deals with communication; it does not specify what is needed for certain applications to run on a device.

3.4 Definitions, Terms and Abbreviations

Abbreviation	Definition
AE	Application Entity
AET	Application Entity Title
ANAP	Attribute not always present
C	Conditional
DICOM	Digital Imaging and Communications in Medicine
ILE	Implicit Little Endian
IOD	Information Object Definition
JPG-1	JPEG Coding Process 1; JPEG Baseline; ISO 10918-1
M	Mandatory
MWL	Modality Work List
NB	Network Broker
RLE	Run Length Encoding
SCP	Service Class Provider
SCU	Service Class User
SOP	Service Object Pair, pair of user and provider.
TCP/IP	Transmission Control Protocol / Internet Protocol
U	User Option
UID	Unique Identifier
VNAP	Value not always present
VL	Visible Light

3.5 References

Digital Imaging and Communications in Medicine (DICOM), NEMA PS 3.1-3.18, 2007.

4 Networking

4.1 Implementation Model

4.1.1 Application Data Flow

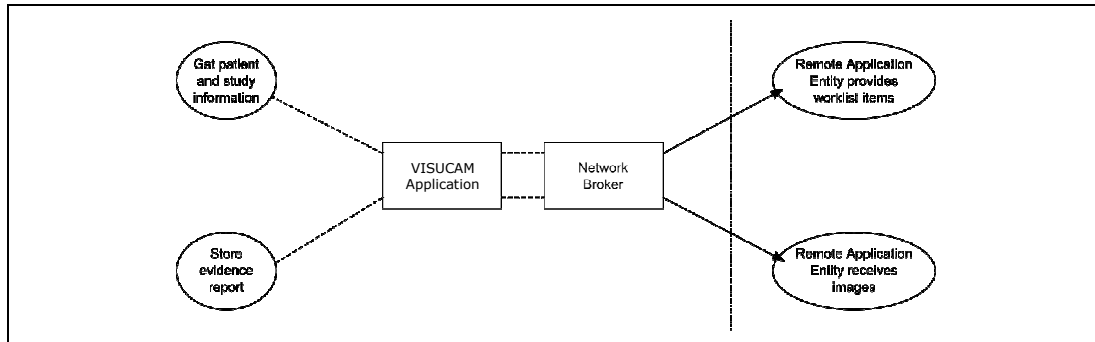

The VISUCAM Software works together with the Network Broker. Both software applications are hosted on same machine. Thus even the User Interface of the Network Broker can be used by an operator which works with the VISUCAM Application.

4.1.2 Functional Definition Of AEs

4.1.2.1 Functional Definition Of Network Broker

The VISUCAM Application allows performing an examination of the eye of a patient, i.e. acquiring data.

4.1.3 Sequencing of Real-World Activities

To realize the real world activities, the different entities work together. The sequence diagrams shall depict the intended workflow.

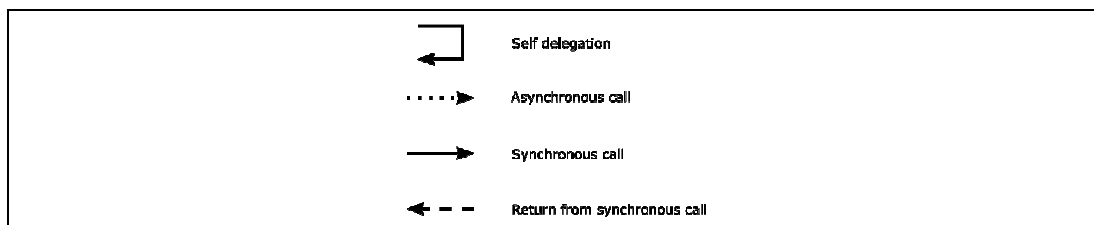

The diagrams uses slightly modified UML symbols. The asynchronous call is not depicted as suggested in UML. Some objects do have more than one dashed line. It symbolizes more than one thread.

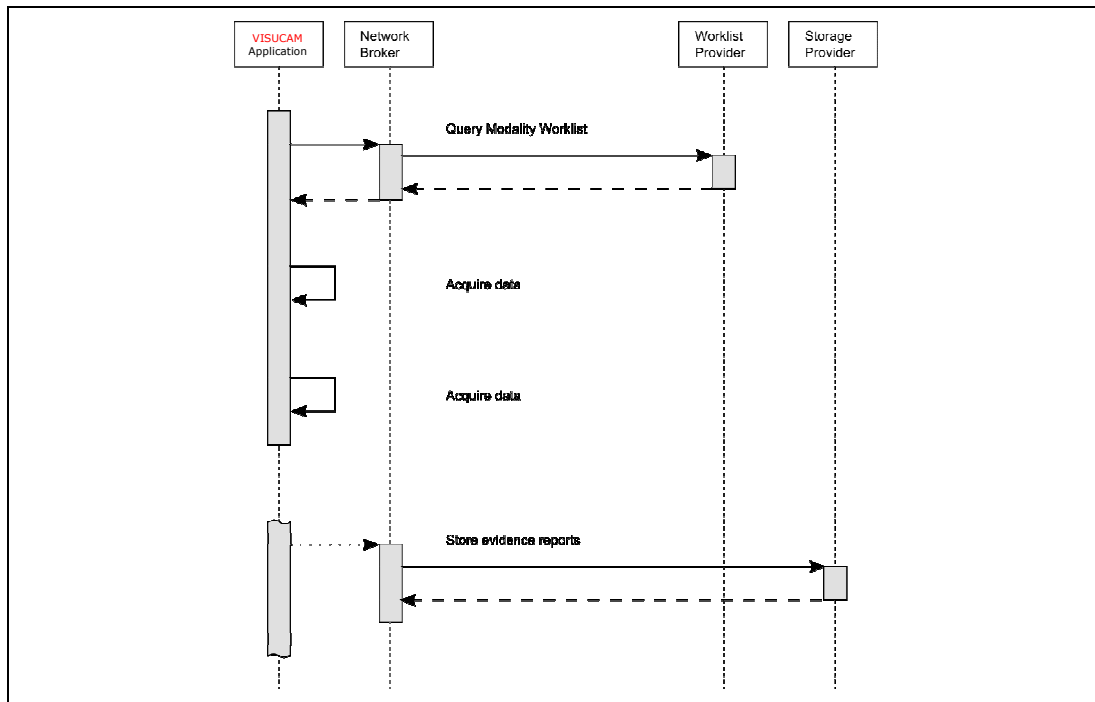

All activities are initiated by an operator.

Query Modality Worklist

When the patient arrives at the **VISUCAM**, then the operator queries the work list. He types in search criterias and gets matches back. Those matches are listed in a table, so the operator can select the correct entry. According to the transferred data **VISUCAM** creates an entry in the local database (Patient, Study, Visit for the current day). Procedure Step related information is kept temporary in the **VISUCAM** application. The operator can now select the patient for data acquisition.

Acquire data

The operator acquires data from patient’s eye.

4.2 AE Specifications

4.2.1 Network Broker Application Entity Specification

4.2.1.1 SOP Classes

SOP Class Name	SOP Class UID	SCU	SCP
Verification	1.2.840.10008.1.1	Yes	No
Modality Worklist Information Model - FIND	1.2.840.10008.5.1.4.31	Yes	No
VL Photographic Image Storage	1.2.840.10008.5.1.4.1.1.77.1.4	Yes	No
Ophthalmic Photography 8 Bit Image Storage	1.2.840.10008.5.1.4.1.1.77.1.5.1	Yes	No

4.2.1.2 Associations Policies

4.2.1.2.1 General

DICOM standard Application Context Name is DICOM 3.0.

Application Context Name	1.2.840.10008.3.1.1.1
--------------------------	-----------------------

4.2.1.2.2 Number of Associations

The number of simultaneous associations results in two since the activities "Query Modality Worklist" and "Store Images" can run in parallel.

Maximum number of simultaneous associations	2
---	---

4.2.1.2.3 Asynchronous Nature

Network Broker does not support asynchronous communication (multiple outstanding transactions over a single Association).

4.2.1.2.4 Implementation Identifying Information

Implementation Class UID	1.2.276.0.75.2.5.10
Implementation Version Name	1.3.2.0547

4.2.1.3 Association Initiation Policy

4.2.1.3.1 Activity – Query Modality Worklist

4.2.1.3.1.1 Description and Sequencing of Activities

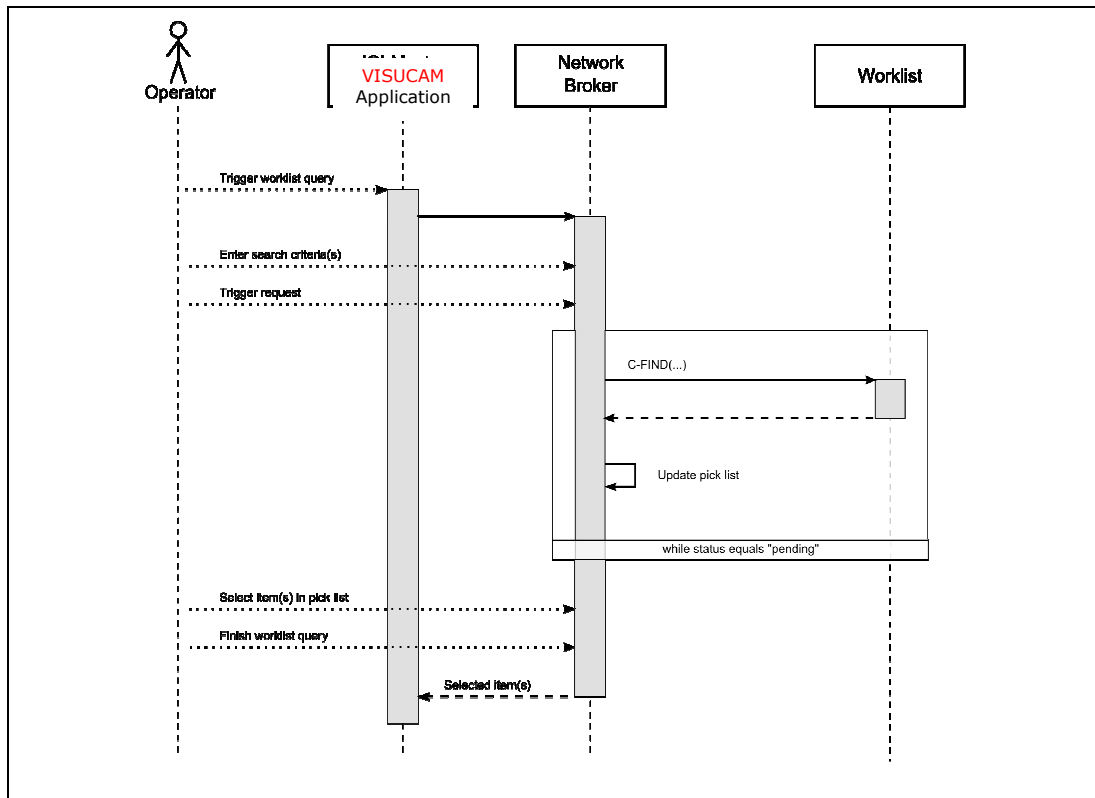

The activity "Query Modality Worklist" can be triggered at any time during the session by operator. It is meaningful to perform the query when the patient comes to the modality, then the work list contains latest information.

After triggering the worklist query, the operator can fill in search criteria in the shown dialog. For instance, incomplete patient information can be used. The operator triggers the search when he or her filled in search criteria. The Network Broker sends a DICOM request, containing the search criteria. Network Broker waits for the response from the partner Application Entity. After receiving the response, Network Broker updates the pick list with the information which is included in the response. The pick list instantly shows the received information. The Network Broker will wait for additional responses as long as the Worklist Provider sends "pending" as status and the number of already received responses does not overstep 50.

After receiving all responses, the operator can select up to a certain number of items to create a new visit for. The number of selectable items can be configured. The operator finally finishes the worklist query by confirming the selection.

The VISUCAM Application takes over the selected items. It prepares data according to the selected items. For patients who relate to existing data sets of the local database, the VISUCAM Application asks the operator to update or to keep the information. For patients who do not relate to existing data sets, the VISUCAM Application creates new data sets. The VISUCAM Application handles data on Study level adequately. Data on Procedure level and Patient – Study level are kept in database. After that, the operator can start examination and to acquire data for those Studies.

4.2.1.3.1.2 Proposed Presentation Contexts

Presentation Context Table					
Abstract Syntax		Transfer Syntax		Role	Ext. Neg.
Name	UID	Name List	UID List		
Modality Worklist Information Model – FIND	1.2.840.10008.5.1.4.31	ILE	1.2.840.10008.1.2	SCU	No

4.2.1.3.1.3 SOP Specific Conformance for Modality Worklist SOP Class

Service Status	Further Meaning	Error Code	Behavior
Success	Matching is complete	0000	The Network Broker finishes receiving worklist items. The user can select items in pick list.
Pending	Matches are continuing	FF00, FF01	Network Broker puts received worklist item into the pick list. If the number of received

			items oversteps 50 then the SCU sends an ABORT to the SCP and the operator gets a request to specify query keys more accurate.
*	*	Any other status code	The status label of the dialog shows an error message.

Tags	Tag Name	Query key, editable by operator	Imported in App from MWL	Displayed in App	Editable	Exported in ImageIOD
Patient						
0010,0010	patients_name	Yes	yes	yes	yes	yes
0010,0020	patient_id	Yes	yes	yes	yes	yes
0010,0021	issuer_of_patient_id		yes	yes ⁽¹⁾	no	yes
0010,0030	patients_birth_date		yes	yes	yes	yes
0010,0032	patients_birth_time		no	no	no	no
0010,0040	patients_sex		yes	yes	yes	yes
0010,1000	other_patient_ids		yes	yes	yes	yes
0010,1001	other_patient_names		no	no	no	no
0010,4000	patient_comments		yes	yes	yes	yes
0010,21C0	pregnancy_status		yes	yes ⁽¹⁾	no	no
0010,2000	medical_alerts		yes	yes ⁽¹⁾	no	no
0010,2110	contrast_allergies		yes	yes ⁽¹⁾	no	no
0038,0050	special_needs		yes	yes ⁽¹⁾	no	no
0038,0500	patient_state		yes	yes ⁽¹⁾	no	no
Study						
(0008,0050)	Accession Number	Yes	yes	yes	no	yes
(0008,0090)	Referring Physicians Name		yes	yes	no	yes
(0020,000D)	Study Instance UID		yes	no	no	yes
(0032,1032)	Requesting Physician		yes	yes ⁽¹⁾	no	yes ^{(1) (2)}
Requested Procedure						
0040,1001	requested_procedure_id		yes	yes ⁽¹⁾	no	yes ⁽¹⁾
0032,1060	requested_procedure_description		yes	yes ⁽¹⁾	no	no
(0032,1064)	Requested Procedure Code Sequence		yes	yes ⁽¹⁾	no	no
(0040,1001)	Requested Procedure ID	yes	yes	yes ⁽¹⁾	no	no
Scheduled Procedure Step (SPS)						
>(0008,0060)	Modality	yes	yes	yes ⁽¹⁾	no	no
>(0040,0001)	Scheduled Station Application Entity Title	no ⁽³⁾	yes	yes ⁽¹⁾	no	no
>(0040,0003)	Scheduled Procedure Step Start Time		yes	yes ⁽¹⁾	no	no
>(0040,0002)	Scheduled Procedure Step Start Date	yes	yes	yes ⁽¹⁾	no	no
>(0040,0006)	Scheduled Performing Physicians Name		yes	yes ⁽¹⁾	no	no
>(0040,0007)	Scheduled Procedure Step Description		yes	yes ⁽¹⁾	no	no
>(0040,0008)	Scheduled Protocol Code Sequence		yes	yes ⁽¹⁾	no	no
>(0040,0009)	Scheduled Procedure Step ID		yes	yes ⁽¹⁾	no	no
(0040,2016)	Placer Order Number Imaging Service Request		no	no	no	no

⁽¹⁾ temporary: as long as MWL-patient is in "waiting room list"

⁽²⁾ stored as physician_of_record; DICOM tag (0008, 1048)

⁽³⁾ will be imported and displayed with NetworkBroker 1.3.4

The operator can fill in search criterions as query keys. Network Broker offers two input masks for it. Following tags are editable as search criteria in input mask "Patient Based Query".

Tag	Description
(0010,0010)	Patients Name
(0010,0020)	Patient ID
(0008,0050)	Accession Number
(0040,1001)	Requested Procedure ID

Following tags are editable as search criteria in input mask "Broad Query".

Tag	Description
(0040,0100)	Scheduled Procedure Step Sequence
>(0040,0002)	Scheduled Procedure Step Start Date
>(0008,0060)	Modality

4.2.1.3.2 Activity – Store images

4.2.1.3.2.1 Description and Sequencing of Activities

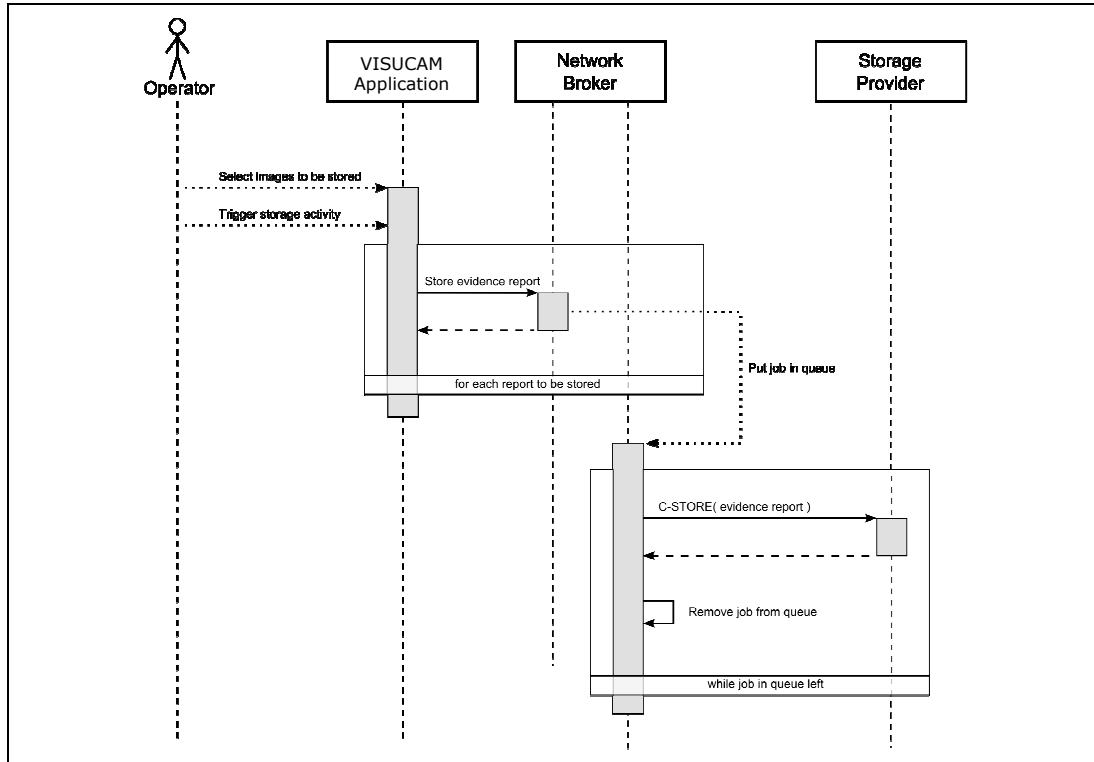

After finishing the examination, the whole Study can be submitted. The operator can initiate sending evidence reports at any time to storage entities.

The VISUCAM Application passes data to the Network Broker. The Network Broker creates immediately DICOM objects and puts a send-job for that DICOM object in a queue. The transmission of the DICOM objects is processed in the background (that means it is performed while operator can continue work with VISUCAM Application).

The storage progress is reflected in a dialog. The operator can even control the storage progress. It's up to the operator if the storage progress dialog is visible or not.

4.2.1.3.2.2 Proposed Presentation Contexts

Presentation Context Table						
Name	Abstract Syntax		Transfer Syntax		Role	Ext. Neg.
	UID		Name List	UID List		
VL Photographic Image Storage	1.2.840.10008.5.1.4.1.1.77.1.4		ILE	1.2.840.10008.1.2	SCU	No
			JPG-1	1.2.840.10008.1.2.4.50	SCU	No
Ophthalmic Photography 8 Bit Image Storage	1.2.840.10008.5.1.4.1.1.77.1.5.1		ILE	1.2.840.10008.1.2	SCU	No
			JPG-1	1.2.840.10008.1.2.4.50	SCU	No

4.2.1.3.2.3 SOP Specific Conformance for Image Storage SOP Class

Service Status	Further Meaning	Error Code	Behavior
Success	Success	0000	The belonging job gets a success state and will be removed from list.
*	*	Any other status code	The job gets an error state.

4.2.1.4 Association Acceptance Policy

The Network Broker does not accept Associations.

4.3 Network Interfaces

4.3.1 Physical Network Interface

The physical network interface is not visible for the applications. The application uses the communication stack as offered by the Operating System.

4.3.2 Additional Protocols

No additional protocols are supported.

4.4 Configuration

4.4.1 AE Title/Presentation Address Mapping

The mapping from AE Title to TCP/IP addresses and ports is configurable and set at the time of installation by Installation Personnel.

4.4.1.1 Local AE Titles

The IP is not configurable by the Network Broker Configuration Tool. The IP is administrated by the Operating System. The calling AET is configurable. The calling AET is the AET of the Network Broker.

4.4.1.2 Remote AE Titles

The mapping of external AE Titles to TCP/IP addresses and ports is configurable. The Network Broker allows setting up one AE as Modality Worklist Provider and one AE as Storage Provider. For both AEs, the host or IP, the Port and the Application Entity Title must be known.

4.4.2 Parameters

4.4.2.1 General Parameters

4.4.2.2 Modality Worklist SCU Parameters

The association initiation timeout is configurable. Default is 10 seconds. Additionally, for this service file-based parameters are available. The file-based parameter describes a template for DICOM objects which is used to perform the request. Whenever the operator performs a request, the Network Broker loads the template file and creates a DICOM object of it. Then the application fills in values which were typed in by the operator in the current active input mask. A dedicated file contains template information for the Modality Worklist Query. By default, the file looks like this:

```
#Specific Character Set
(0008,0005)

#Scheduled Procedure Step Sequence
#(0040,0100)
#Scheduled Station AE Title
(0040,0100) [0]>(0040,0001)
#Scheduled Step Start Date
(0040,0100) [0]>(0040,0002)
#Scheduled Step Start Time
(0040,0100) [0]>(0040,0003)
#Modality
(0040,0100) [0]>(0008,0060)
#Scheduled Performing Physicians Name
(0040,0100) [0]>(0040,0006)
#Scheduled Procedure Step Description
(0040,0100) [0]>(0040,0007)
#Scheduled Station Name
(0040,0100) [0]>(0040,0010)
#Scheduled Procedure Step Location
(0040,0100) [0]>(0040,0011)

#Scheduled Action Item Code Sequence
#(0040,0100)>(0040,0008)
#Code Value (Sequence)
(0040,0100) [0]>(0040,0008) [0]>(0008,0100)
#Coding Scheme Version
(0040,0100) [0]>(0040,0008) [0]>(0008,0103)
#Coding Scheme Designator
(0040,0100) [0]>(0040,0008) [0]>(0008,0102)
#Coding Meaning
(0040,0100) [0]>(0040,0008) [0]>(0008,0104)

#Pre-Medication
(0040,0100) [0]>(0040,0012)
#Scheduled Procedure Step ID
```

(0040,0100) [0]>(0040,0009)
#Requested Contrast Agent
(0040,0100) [0]>(0032,1070)
#Requested Procedure Step Status
(0040,0100) [0]>(0040,0020)

#Requested Procedure ID
(0040,1001)
#Requested Procedure Description
(0032,1060)

#Requested Procedure Code Sequence
#(0032,1064)
#Code Value
(0032,1064) [0]>(0008,0100)
#Coding Scheme Designator
(0032,1064) [0]>(0008,0102)
#Coding Scheme Version
(0032,1064) [0]>(0008,0103)
#Code Meaning
(0032,1064) [0]>(0008,0104)

#Study Instance UID
(0020,000D)
#Study Comments
(0032,4000)

#Referenced Study Sequence
#(0008,1110)
#Referenced SOP Class UID
(0008,1110) [0]>(0008,1150)
#Referenced SOP Instance UID
(0008,1110) [0]>(0008,1155)

#Requested Procedure Priority
(0040,1003)
#Patient Transport Arrangements
(0040,1004)
#Accession Number
(0008,0050)
#Requesting Physician
(0032,1032)
#Referring Physician's Name
(0008,0090)
#Placer Order Number / Imaging Service Request
(0040,2016)
#Admission ID
(0038,0010)
#Current Patient Location
(0038,0300)

#Referenced Patient Sequence
#(0008,1120)
#Referenced SOP Class UID
(0008,1120) [0]>(0008,1150)
#Referenced SOP Instance UID
(0008,1120) [0]>(0008,1155)

#Patient's Name
(0010,0010)
#Patient ID
(0010,0020)
#Issuer of Patient ID
(0010,0021)
#Other Patient IDs
(0010,1000)
#Other Patient Names
(0010,1001)
#Patients Birth Date
(0010,0030)
#Patients Birth Time
(0010,0032)
#Patient's Sex
(0010,0040)
#Patients's Weight
(0010,1030)

#Confidentiality constraint on patient data
(0040,3001)
#Patient State
(0038,0500)
#Ethnic Group
(0010,2160)
#Patient Comments
(0010,4000)
#Pregnancy Status
(0010,21C0)
#Medical Alerts
(0010,2000)
#Contrast Allergies
(0010,2110)
#Special Needs
(0038,0050)

4.4.2.3 Storage SCU Parameters

The association initiation timeout is configurable. Default is 10 seconds.

For VISUCAM the selectable compressions for the IODs are:

- VL Photographic
 - No Compression
 - JPEG Baseline Compression
- Ophthalmic Photography 8 Bit
 - No Compression
 - JPEG Baseline Compression

5 Media Interchange

Media Interchange is not scope of this document since Media Interchange is not supported via Network Broker.
For DICOM File I/O see separate document:
'DICOM Conformance Statement – Offline media storage support'

6 Support of Character Sets

In addition to the default character repertoire, the Defined Terms for Specific Character Set in the table are supported.

Supported Specific Character Set	
Character Set Description	Defined Term
Latin alphabet No. 1	ISO_IR 100

7 Security

The DICOM capabilities of the VISUCAM Application do not support any specific security measures.

It is assumed that VISUCAM Application is used within a secured environment. It is assumed that a secured environment includes at a minimum:

- Firewall or router protections to ensure that only approved external hosts have network access to VISUCAM Application.
- Firewall or router protections to ensure that VISUCAM Application only has network access to approved external hosts and services.
- Any communication with external hosts and services outside the locally secured environment use appropriate secure network channels (e.g. such as a Virtual Private Network (VPN))

Other network security procedures such as automated intrusion detection may be appropriate in some environments. Additional security features may be established by the local security policy and are beyond the scope of this conformance statement.

8 Annexes

8.1 IOD Contents

8.1.1 Created SOP Instance(s)

The rows of not supported modules are grayed.

8.1.1.1 Ophthalmic Photography

A.41.3 Ophthalmic Photography 8 Bit Image IOD Modules				
Table A.41-1 OPHTHALMIC PHOTOGRAPHY 8 BIT IMAGE IOD MODULES				
IE	Module	Reference	Usage	
Patient	Patient	C.7.1.1	M	
	Specimen Identification	C.7.1.2	C - Required if the Imaging Subject is a Specimen	
	Clinical Trial Subject	C.7.1.3	U	
Study	General Study	C.7.2.1	M	
	Patient Study	C.7.2.2	U	
	Clinical Trial Study	C.7.2.3	U	
Series	General Series	C.7.3.1	M	
	Ophthalmic Photography Series	C.8.17.1	M	
	Clinical Trial Series	C.7.3.2	U	
Frame of Reference	Synchronization	C.7.4.2	M	
Equipment	General Equipment	C.7.5.1	M	
Image	General Image	C.7.6.1	M	
	Image Pixel	C.7.6.3	M	
	Enhanced Contrast/Bolus	C.7.6.4b	C - Required if contrast was administered, see A.41.4.2	
	Cine	C.7.6.5	C - Required if there is a sequential temporal relationship between all frames	
	Multi-frame	C.7.6.6	M	
	Device	C.7.6.12	U	
	Ophthalmic Photography Image	C.8.17.2	M	
	Ocular Region Imaged	C.8.17.5	M	
	Ophthalmic Photography Acquisition Parameters	C.8.17.4	M	
	Ophthalmic Photographic Parameters	C.8.17.3	M	
SOP Common	C.12.1	M		

Tag	VR	Name	Value	Presence of Value	Source
Information Entity 'Patient'					
Module 'Patient'					
(0008,1120)	SQ	Referenced Patient Sequence	A sequence that provides reference to a Patient SOP Class/Instance pair. Only a single Item shall be permitted in this Sequence.	ALWAYS	AUTO
>(0008,1150)	UI	Referenced SOP Class UID	Uniquely identifies the referenced SOP Class. Required if	ALWAYS	AUTO

				Referenced Patient Sequence (0008,1120) is sent.		
	>(0008,1155)	UI	Referenced SOP Instance UID	Uniquely identifies the referenced SOP Instance. Required if Referenced Patient Sequence (0008,1120) is sent.	ALWAYS	AUTO
	(0010,0010)	PN	Patient's Name	Patient's full name.	ALWAYS	MWL, USER
	(0010,0020)	LO	Patient ID	Primary hospital identification number or code for the patient.	ALWAYS	MWL, USER
	(0010,0021)	LO	Issuer of Patient ID	Identifier of the Assigning Authority that issued the Patient ID.	VNAP	MWL
	(0010,0030)	DA	Patient's Birth Date	Birth date of the patient.	ALWAYS	MWL, USER
	(0010,0040)	CS	Patient's Sex	Sex of the named patient. Enumerated Values: M = male F = female O = other	VNAP	MWL, USER
	(0010,1000)	LO	Other Patient IDs	Other identification numbers or codes used to identify the patient.	VNAP	MWL
	(0010,1001)	PN	Other Patient Names	Other names used to identify the patient.	NEVER	
	(0010,2160)	SH	Ethnic Group	Ethnic group or race of the patient.	VNAP	MWL
	(0010,4000)	LT	Patient Comments	User-defined additional information about the patient.	VNAP	MWL, USER
Information Entity 'Study'						
Module 'General Study'						
	(0008,0020)	DA	Study Date	Date the Study started.	ALWAYS	MWL, USER
	(0008,0030)	TM	Study Time	Time the Study started.	VNAP	USER
	(0008,0050)	SH	Accession Number	A RIS generated number that identifies the order for the Study.	ALWAYS	MWL
	(0008,0090)	PN	Referring Physician's Name	Name of the patient's referring physician	VNAP	MWL
	(0008,1030)	LO	Study Description	Institution-generated description or classification of the Study (component) performed.	VNAP	MWL
	(0008,1048)	PN	Physician(s) of Record	Names of the physician(s) who are responsible for overall patient care at time of Study (see Section C.7.3.1 for Performing Physician)	VNAP	MWL, AUTO
	(0020,000D)	UI	Study Instance UID	Unique identifier for the Study.	ALWAYS	AUTO, MWL
	(0020,0010)	SH	Study ID	User or equipment generated Study identifier.	ALWAYS	AUTO
Module 'Patient Study'						
Information Entity 'Series'						
Module 'General Series'						
	(0008,0021)	DA	Series Date	Date the Series started.	ALWAYS	AUTO
	(0008,0031)	TM	Series Time	Time the Series started.	ALWAYS	AUTO
	(0008,1070)	PN	Operators' Name	Name(s) of the operator(s) supporting the Series.	VNAP	CONFIG

	(0018,0015)	CS	Body Part Examined	<p>"HEAD"</p> <p><i>Text description of the part of the body examined. Defined Terms: SKULL, CSPINE, TSPINE, LSPINE, SSPINE, COCCYX, CHEST, CLAVICLE, BREAST, ABDOMEN, PELVIS, HIP, SHOULDER, ELBOW, KNEE, ANKLE, HAND, FOOT, EXTREMITY, HEAD, HEART, NECK, LEG, ARM, JAW</i></p> <p><i>Note: Some IODs support the Anatomic Region Sequence (0008,2218), which can provide a more comprehensive mechanism for specifying the body part being examined.</i></p>	ALWAYS	FIXED
	(0020,000E)	UI	Series Instance UID	The UID starts with "1.2.276.0.75.2.1.20.0."	ALWAYS	AUTO
	(0020,0011)	IS	Series Number	A number that identifies this Series.	ALWAYS	AUTO
	(0020,0060)	CS	Laterality	Empty. Image Laterality (0020,0062) is more comprehensive.	ALWAYS	AUTO
Module 'Ophthalmic Photography Series'						
	(0008,0060)	CS	Modality	"OP"	ALWAYS	AUTO
Module 'Clinical Trial Series'						
Information Entity 'Frame of Reference'						
Module 'Synchronization'						
	(0018,106A)	CS	Synchronization Trigger	"NO TRIGGER" - data acquisition is not synchronized by common channel or trigger.	ALWAYS	AUTO
	(0018,1800)	CS	Acquisition Time Synchronized	"N " - Acquisition Datetime (0008,002A) is not synchronized with external time reference.	ALWAYS	AUTO
	(0020,0200)	UI	Synchronization Frame of Reference UID	The UID is valid from Instrument Application's start-up til shut down. The internal clock can be adjusted by service personel only. After adjusting the internal clock, the service member restarts the Instrument Application. So it is guaranteed the UID represents one single Synchronization Frame of Reference.	ALWAYS	AUTO
Information Entity 'Equipment'						
Module 'General Equipment'						
	(0008,0070)	LO	Manufacturer	"Carl Zeiss Meditec AG"	ALWAYS	AUTO
	(0008,0080)	LO	Institution Name	Institution where the equipment that produced the composite instances is located.	VNAP	CONFIG
	(0008,0081)	ST	Institution Address	Mailing address of the institution where the equipment that produced the composite instances is located.	VNAP	CONFIG
	(0008,1010)	SH	Station Name	User defined name identifying the machine that produced the composite instances.	VNAP	CONFIG
	(0008,1040)	LO	Institutional	Department in the institution	VNAP	CONFIG

			Department Name	where the equipment that produced the composite instances is located.		
	(0008,1090)	LO	Manufacturer's Model Name	Manufacturer's model name of the equipment that produced the composite instances.	VNAP	CONFIG
	(0018,1000)	LO	Device Serial Number	Manufacturer's serial number of the equipment that produced the composite instances. Note: This identifier corresponds to the device that actually created the images, such as a CR plate reader or a CT console, and may not be sufficient to identify all of the equipment in the imaging chain, such as the generator or gantry or plate.	VNAP	AUTO
	(0018,1020)	LO	Software Versions	Manufacturer's designation of software version of the equipment that produced the composite instances.	ALWAYS	AUTO
	(0018,1050)	DS	Spatial Resolution	The inherent limiting resolution in mm of the acquisition equipment for high contrast objects for the data gathering and reconstruction technique chosen. If variable across the images of the series, the value at the image center.	VNAP	AUTO
Information Entity 'Image'						
Module 'General Image'						
	(0008,0022)	DA	Acquisition Date	The date the acquisition of data that resulted in this image started	VNAP	CONFIG
	(0008,0032)	TM	Acquisition Time	The time the acquisition of data that resulted in this image started	VNAP	CONFIG
	(0008,0033)	TM	Content Time	Overwrote by Module 'Ophthalmic Photography Image'		
	(0008,2111)	ST	Derivation Description	A text description of how this image was derived. See C.7.6.1.1.3 for further explanation.	VNAP	AUTO
	(0008,2112)	SQ	Source Image Sequence	Overwrote by Module 'Ophthalmic Photography Image'		
	>(0008,1150)	UI	Referenced SOP Class UID	Overwrote by Module 'Ophthalmic Photography Image'		
	>(0008,1155)	UI	Referenced SOP Instance UID	Overwrote by Module 'Ophthalmic Photography Image'		
	>(0008,1160)	IS	Referenced Frame Number	Overwrote by Module 'Ophthalmic Photography Image'		
	>(0020,0020)	CS	Patient Orientation	Overwrote by Module 'Ophthalmic Photography Image'		
	>(0028,135A)	CS	Spatial Locations Preserved	Overwrote by Module 'Ophthalmic Photography Image'		
	>(0040,A170)	SQ	Purpose of Reference Code Sequence	Overwrote by Module 'Ophthalmic Photography Image'		
	>>(0008,0100)	SH	Code Value	Overwrote by Module 'Ophthalmic Photography Image'		

>>(0008,0102)	SH	Coding Scheme Designator	Overwrote by Module 'Ophthalmic Photography Image'		
>>(0008,0103)	SH	Coding Scheme Version	Overwrote by Module 'Ophthalmic Photography Image'		
>>(0008,0104)	LO	Code Meaning	Overwrote by Module 'Ophthalmic Photography Image'		
>>(0008,0105)	CS	Mapping Resource	Overwrote by Module 'Ophthalmic Photography Image'		
>>(0008,0106)	DT	Context Group Version	Overwrote by Module 'Ophthalmic Photography Image'		
>>(0008,0107)	DT	Context Group Local Version	Overwrote by Module 'Ophthalmic Photography Image'		
>>(0008,010B)	CS	Context Group Extension Flag	Overwrote by Module 'Ophthalmic Photography Image'		
>>(0008,010D)	UI	Context Group Extension Creator UID	Overwrote by Module 'Ophthalmic Photography Image'		
>>(0008,010F)	CS	Context Identifier	Overwrote by Module 'Ophthalmic Photography Image'		
>(0062,000B)	US	Referenced Segment Number	Overwrote by Module 'Ophthalmic Photography Image'		
(0020,0012)	IS	Acquisition Number	A number identifying the single continuous gathering of data over a period of time that resulted in this image.	VNAP	AUTO
(0020,0013)	IS	Instance Number	Overwrote by Module 'Ophthalmic Photography Image'		
(0020,0020)	CS	Patient Orientation	Patient direction of the rows and columns of the image. Required if image does not require Image Orientation (Patient) (0020,0037) and Image Position (Patient) (0020,0032). See C.7.6.1.1.1 for further explanation. Note: IOD's may have attributes other than Patient Orientation, Image Orientation, or Image Position (Patient) to describe orientation in which case this attribute will be zero length.	VNAP	AUTO
(0020,4000)	LT	Image Comments	User-defined comments about the image		
(0028,0301)	CS	Burned In Annotation	Indicates whether or not image contains sufficient burned in annotation to identify the patient and date the image was acquired. Enumerated Values: YES, NO If this Attribute is absent, then the image may or may not contain burned in annotation.	ALWAYS "NO"	FIXED
(0028,2110)	CS	Lossy Image Compression	Overwrote by Module 'Ophthalmic Photography Image'	VNAP	AUTO
(0028,2112)	DS	Lossy Image Compression Ratio	Overwrote by Module 'Ophthalmic Photography Image'	VNAP	AUTO
(2050,0020)	CS	Presentation LUT Shape	Overwrote by Module 'Ophthalmic Photography Image'		
Module 'Image Pixel'					
(0028,0002)	US	Samples per Pixel	Overwrote by Module		

				'Ophthalmic Photography Image'		
	(0028,0004)	CS	Photometric Interpretation	Overwrote by Module 'Ophthalmic Photography Image'		
	(0028,0006)	US	Planar Configuration	Overwrote by Module 'Ophthalmic Photography Image'		
	(0028,0010)	US	Rows	"1024"	ALWAYS	AUTO
	(0028,0011)	US	Columns	"1280"	ALWAYS	AUTO
	(0028,0100)	US	Bits Allocated	"8"	ALWAYS	AUTO
	(0028,0101)	US	Bits Stored	"8"	ALWAYS	AUTO
	(0028,0102)	US	High Bit	"7"	ALWAYS	AUTO
	(0028,0103)	US	Pixel Representation	Overwrote by Module 'Ophthalmic Photography Image'		
	(7FE0,0010)	OW /OB	Pixel Data		ALWAYS	AUTO
Module 'Enhanced Contrast/Bolus'						
	(0018,0012)	SQ	Contrast/Bolus Agent Sequence	Contains zero or one item. Sequence that identifies one or more contrast agents administered prior to or during the acquisition. Shall contain one or more Items. Included macro 'Code Sequence Macro', context 'Baseline Context ID is 12.'	ANAP	FA, ICG
	>(0008,0100)	SH	Code Value	"C-B02CC"	ANAP	FA, ICG
	>(0008,0102)	SH	Coding Scheme Designator	"SRT"	ANAP	FA, ICG
	>(0008,0103)	SH	Coding Scheme Version	"20040921"	ANAP	FA, ICG
	>(0008,0104)	LO	Code Meaning	"Fluorescein"	ANAP	FA, ICG
	>(0018,0014)	SQ	Contrast/Bolus Administration Route Sequence	Contains one item. Sequence that identifies the route of administration of contrast agent. Shall contain exactly one Item. Included macro 'Code Sequence Macro', context 'Baseline Context ID is 11.'	ANAP	FA, ICG
	>>(0008,0100)	SH	Code Value	"G-D101"	ANAP	FA, ICG
	>>(0008,0102)	SH	Coding Scheme Designator	"SNM3"	ANAP	FA, ICG
	>>(0008,0104)	LO	Code Meaning	"Intravenous route"	ANAP	FA, ICG
	>(0018,1041)	DS	Contrast/Bolus Volume	Exists for conformance, but empty.	ANAP	FA, ICG
	>(0018,1041)	DS	Contrast/Bolus Volume	Exists for conformance, but empty.	ANAP	FA, ICG
	>(0018,9337)	US	Contrast/Bolus Agent Number	"1" because at maximum there is one item in this sequence.	ANAP	FA, ICG
	>(0018,9338)	SQ	Contrast/Bolus Ingredient Code Sequence	Exists for conformance, but empty. Active ingredient of agent. Zero or more Items may be included in the Sequence. Included macro 'Code Sequence	ANAP	FA, ICG

				Macro', context 'Baseline Context ID is 13.'		
	>(0018,9340)	SQ	Contrast Administration Profile Sequence	Sequence that describes one or more phases of contrast administered. If present, shall contain one or more Items.	ANAP	FA, ICG
	>>(0018,1041)	DS	Contrast/Bolus Volume	Exists for conformance, but empty. Volume administered during this phase in milliliters of diluted contrast agent.	ANAP	FA, ICG
	>>(0018,1042)	TM	Contrast/Bolus Start Time	Time of start of administration.	ANAP	FA, ICG
Module 'Cine'						
Module 'Multi-frame'						
	(0028,0008)	IS	Number of Frames	"1" – the VISUCAM does not create multi-frame images	ALWAYS	AUTO
	(0028,0009)	AT	Frame Increment Pointer	"(0018,2001)"	ALWAYS	AUTO
Module 'Device'						
Module 'Ophthalmic Photography Image'						
	(0008,0008)	CS	Image Type	Image identification characteristics. 4 items: 1. "ORIGINAL", "DERIVED" 2. "PRIMARY", "SECONDARY" 3. 4. "AF", "FA", "ICG", "COLOR", "RED", "BLUE", "GREEN", "MONTAGE"	VNAP	AUTO
	(0008,0023)	DA	Content Date	The date the image pixel data creation started.	VNAP	AUTO
	(0008,002A)	DT	Acquisition Datetime	The date and time that the acquisition of data started. Note: The synchronization of this time with an external clock is specified in the synchronization Module in Acquisition Time Synchronized (0018,1800). Required if Image Type (0008,0008) Value 1 is ORIGINAL. May be present otherwise.	VNAP	AUTO
	(0008,0033)	TM	Content Time	The time the image pixel data creation started.	VNAP	AUTO
	(0020,0013)	IS	Instance Number	A number that identifies this image.	VNAP	AUTO
	(0028,0002)	US	Samples per Pixel	"1" – for monochrome images "3" – for color images	ALWAYS	AUTO
	(0028,0004)	CS	Photometric Interpretation	"MONOCHROME2" – for monochrome images. "RGB" – for color images. "YBR_FULL_422" – for JPEG Baseline compressed images.	ALWAYS	CONFIG, AUTO
	(0028,0006)	US	Planar Configuration	"0" - color-by-pixel Exists if Samples per Pixel (0028,0002) has a value greater	ANAP	AUTO

				than 1.		
	(0028,0030)	DS	Pixel Spacing	Present because Acquisition Device Type Code Sequence (0022,0015) contains an item with the value (SRT, R-1021A, "Fundus Camera"). Values depend on chosen visible angle.	ALWAYS	AUTO
	(0028,0103)	US	Pixel Representation	"0"	ALWAYS	AUTO
	(0028,0301)	CS	Burned In Annotation	"NO"	ALWAYS	AUTO
	(0028,2110)	CS	Lossy Image Compression	Specifies whether an Image has undergone lossy compression. "00" - Image has not been subjected to lossy compression. "01" - Image has been subjected to lossy compression.	ALWAYS	CONFIG, AUTO
	(0028,2112)	DS	Lossy Image Compression Ratio	Describes the approximate lossy compression ratio(s) that have been applied to this image. See C.7.6.1.1.5 for further explanation. May be multivalued if successive lossy compression steps have been applied. Notes: 1. For example, a compression ratio of 30:1 would be described in this Attribute with a single value of 30. 2. For historical reasons, the lossy compression ratio may also be described in Derivation Description (0008,2111). Required if Lossy Image Compression (0028,2110) has a value of "01".	ANAP	CONFIG, AUTO
	(0028,2114)	CS	Lossy Image Compression Method	"ISO_10918_1" <i>A label for the lossy compression method(s) that have been applied to this image. See C.7.6.1.1.5 for further explanation. May be multivalued if successive lossy compression steps have been applied; the value order shall correspond to the values of Lossy Image Compression Ratio (0028,2112). Required if Lossy Image Compression (0028,2110) has a value of "01". Note: For historical reasons, the lossy compression method should also be described in Derivation Description (0008,2111).</i>	ANAP	CONFIG, AUTO
	(2050,0020)	CS	Presentation LUT Shape	"IDENTITY" - Exists if Photometric Interpretation (0028,0004) is "MONOCHROME2"	ANAP	AUTO
Module 'Ocular Region Imaged'						
	(0008,2218)	SQ	Anatomic Region Sequence	One item present <i>Sequence that identifies the anatomic region of interest in this Instance (i.e. external anatomy, surface anatomy, or general region of the body). Only a single Item shall be permitted in this sequence.</i>	ALWAYS	AUTO

	>(0008,0100)	SH	Code Value	"T-AA000"	ALWAYS	AUTO
	>(0008,0102)	SH	Coding Scheme Designator	"SRT"	ALWAYS	AUTO
	>(0008,0104)	LO	Code Meaning	"Eye"	ALWAYS	AUTO
	(0020,0062)	CS	Image Laterality	Laterality of object imaged (as described in Anatomic Region Sequence (0008,2218)) examined. Enumerated Values: R = right eye L = left eye B = both left and right eye Shall be consistent with any laterality information contained in Primary Anatomic Structure Modifier Sequence (0008,2230), if present. Note: Laterality (0020,0060) is a Series level Attribute and must be the same for all Images in the Series. Since most Ophthalmic Photographic Image studies contain images of both eyes, the series level attribute will rarely be present.	ALWAYS	AUTO
Module 'Ophthalmic Photography Acquisition Parameters'						
	(0022,0005)	CS	Patient Eye Movement Commanded	Empty, exists because of conformance.	VNAP	AUTO
	(0022,000A)	FL	Emmetropic Magnification	Empty, exists because of conformance. <i>Emmetropic Magnification value (dimensionless). Zero length means the emmetropic magnification was not measured.</i>	ALWAYS	AUTO
	(0022,000B)	FL	Intra Ocular Pressure	Empty, exists because of conformance. <i>Value of pressure. Value in mmHg. Zero length means the pressure was not measured.</i>	ALWAYS	AUTO
	(0022,000C)	FL	Horizontal Field of View	The horizontal field of view in degrees	ALWAYS	AUTO
	(0022,000D)	CS	Pupil Dilated	"NO" <i>Enumerated Values: YES, NO</i>	ALWAYS	AUTO
Module 'Ophthalmic Photographic Parameters'						
	(0018,7004)	CS	Detector Type	Empty. <i>Type of detector used for creating this image. Defined terms: CCD = Charge Coupled Devices CMOS = Complementary Metal Oxide Semiconductor</i>	ALWAYS	AUTO
	(0022,0015)	SQ	Acquisition Device Type Code Sequence	One item. <i>Describes the type of acquisition device. A single item shall be present in the sequence. Included macro 'Code Sequence Macro', context 'Baseline Context ID is 4202'</i>	ALWAYS	AUTO
	>(0008,0100)	SH	Code Value	"R-1021A"	ALWAYS	AUTO
	>(0008,0102)	SH	Coding Scheme	"SRT"	ALWAYS	AUTO

			Designator			
	>(0008,0104)	LO	Code Meaning	"Fundus Camera"	ALWAYS	AUTO
	(0022,0016)	SQ	Illumination Type Code Sequence	<p>Contains no item. Exists because of conformance.</p> <p><i>Coded value for illumination. Zero or one item shall be present in the sequence. Included macro 'Code Sequence Macro', context 'Baseline Context ID is 4203'</i></p>	ALWAYS	AUTO
	(0022,0017)	SQ	Light Path Filter Type Stack Code Sequence	<p>Contains no item. Exists because of conformance.</p> <p><i>Filters used in the light source path. Zero or more items may be present in the sequence. Included macro 'Code Sequence Macro', context 'Baseline Context ID is 4204'</i></p>	ALWAYS	AUTO
	(0022,0018)	SQ	Image Path Filter Type Stack Code Sequence	<p>Contains no item. Exists because of conformance.</p> <p><i>Describes stack of filters used in image path. Zero or more items may be present in the sequence. Included macro 'Code Sequence Macro', context 'Baseline Context ID is 4204'</i></p>	ALWAYS	AUTO
	(0022,0019)	SQ	Lenses Code Sequence	<p>Contains no item. Exists because of conformance.</p> <p><i>Lenses that were used during the image acquisition. Zero or more items may be present in the sequence. Included macro 'Code Sequence Macro', context 'Baseline Context ID is 4205'</i></p>	ALWAYS	AUTO
Module 'SOP Common'						
	(0008,0005)	CS	Specific Character Set	ISO_IR 100 Character Set that expands or replaces the Basic Graphic Set.	ALWAYS	AUTO
	(0008,0016)	UI	SOP Class UID	"1.2.840.10008.5.1.4.1.1.77.1.5.1"	ALWAYS	AUTO
	(0008,0018)	UI	SOP Instance UID	Uniquely identifies the SOP Instance. See C.12.1.1.1 for further explanation. See also PS 3.4.	ALWAYS	AUTO
	(0020,0013)	IS	Instance Number	A number that identifies this Composite object instance.	ALWAYS	AUTO

8.1.1.2 Visible Light

A.32.4 VL Photographic Image Information Object Definition				
Table A.32.4-1 VL PHOTOGRAPHIC IMAGE IOD MODULES				
	IE	Module	Reference	Usage
	Patient	Patient	C.7.1.1	M
		Specimen Identification	C.7.1.2	C - Required if the Imaging Subject is a Specimen
		Clinical Trial Subject	C.7.1.3	U
	Study	General Study	C.7.2.1	M
		Patient Study	C.7.2.2	U
		Clinical Trial Study	C.7.2.3	U
	Series	General Series	C.7.3.1	M
		Clinical Trial Series	C.7.3.2	U
	Equipment	General Equipment	C.7.5.1	M
	Image	General Image	C.7.6.1	M
		Image Pixel	C.7.6.3	M
		Acquisition Context	C.7.6.14	M
		Device	C.7.6.12	U
		VL Image	C.8.12.1	M
		Overlay Plane	C.9.2	U
		SOP Common	C.12.1	M

Tag	VR	Name	Value	Presence of Value	Source
Information Entity 'Patient'					
Module 'Patient'					
(0008,1120)	SQ	Referenced Patient Sequence	A sequence that provides reference to a Patient SOP Class/Instance pair. Only a single Item shall be permitted in this Sequence.	ALWAYS	AUTO
>(0008,1150)	UI	Referenced SOP Class UID	Uniquely identifies the referenced SOP Class. Required if Referenced Patient Sequence (0008,1120) is sent.	ALWAYS	AUTO
>(0008,1155)	UI	Referenced SOP Instance UID	Uniquely identifies the referenced SOP Instance. Required if Referenced Patient Sequence (0008,1120) is sent.	ALWAYS	AUTO
(0010,0010)	PN	Patient's Name	Patient's full name.	ALWAYS	MWL, USER
(0010,0020)	LO	Patient ID	Primary hospital identification number or code for the patient.	ALWAYS	MWL, USER
(0010,0021)	LO	Issuer of Patient ID	Identifier of the Assigning Authority that issued the Patient ID.	VNAP	MWL
(0010,0030)	DA	Patient's Birth Date	Birth date of the patient.	ALWAYS	MWL, USER
(0010,0032)	TM	Patient's Birth Time	Birth time of the Patient.		
(0010,0040)	CS	Patient's Sex	Sex of the named patient. Enumerated Values: M = male F	VNAP	MWL, USER

				= female O = other		
	(0010,1000)	LO	Other Patient IDs	Other identification numbers or codes used to identify the patient.	VNAP	MWL
	(0010,1001)	PN	Other Patient Names	Other names used to identify the patient.	NEVER	
	(0010,2160)	SH	Ethnic Group	Ethnic group or race of the patient.	VNAP	MWL
	(0010,4000)	LT	Patient Comments	User-defined additional information about the patient.	VNAP	MWL, USER
Module 'Specimen Identification'						
Module 'Clinical Trial Subject'						
Information Entity 'Study'						
Module 'General Study'						
	(0008,0020)	DA	Study Date	Date the Study started.	ALWAYS	MWL, USER
	(0008,0030)	TM	Study Time	Time the Study started.	VNAP	USER
	(0008,0050)	SH	Accession Number	A RIS generated number that identifies the order for the Study.	ALWAYS	MWL
	(0008,0090)	PN	Referring Physician's Name	Name of the patient's referring physician	VNAP	MWL
	(0008,1030)	LO	Study Description	Institution-generated description or classification of the Study (component) performed.	VNAP	USER, MWL
	(0008,1048)	PN	Physician(s) of Record	Names of the physician(s) who are responsible for overall patient care at time of Study (see Section C.7.3.1 for Performing Physician)	VNAP	AUTO
	(0020,000D)	UI	Study Instance UID	Unique identifier for the Study.	ALWAYS	AUTO, MWL
	(0020,0010)	SH	Study ID	User or equipment generated Study identifier.	VNAP	AUTO
Module 'Patient Study'						
Module 'Clinical Trial Study'						
Information Entity 'Series'						
Module 'General Series'						
	(0008,0021)	DA	Series Date	Date the Series started.	VNAP	AUTO
	(0008,0031)	TM	Series Time	Time the Series started.	VNAP	AUTO
	(0008,0060)	CS	Modality	Type of equipment that originally acquired the data used to create the images in this Series. See C.7.3.1.1.1 for Defined Terms.	ALWAYS	AUTO
	(0008,103E)	LO	Series Description	User provided description of the Series	VNAP	AUTO
	(0008,1050)	PN	Performing Physicians' Name	Name of the physician(s) administering the Series.	VNAP	AUTO
	(0008,1070)	PN	Operators' Name	Name(s) of the operator(s) supporting the Series.	VNAP	AUTO
	(0018,0015)	CS	Body Part Examined	"HEAD" <i>Text description of the part of the body examined. Defined Terms: SKULL, CSPINE, TSPINE, LSPINE, SSPINE, COCCYX, CHEST,</i>		

				<p>CLAVICLE, BREAST, ABDOMEN, PELVIS, HIP, SHOULDER, ELBOW, KNEE, ANKLE, HAND, FOOT, EXTREMITY, HEAD, HEART, NECK, LEG, ARM, JAW</p> <p>Note: Some IODs support the Anatomic Region Sequence (0008,2218), which can provide a more comprehensive mechanism for specifying the body part being examined.</p>		
	(0020,000E)	UI	Series Instance UID	Unique identifier of the Series.	ALWAYS	AUTO
	(0020,0011)	IS	Series Number	A number that identifies this Series.	ALWAYS	AUTO
	(0020,0060)	CS	Laterality	<p>Laterality of (paired) body part examined. Required if the body part examined is a paired structure and Image Laterality (0020,0062) or Frame Laterality (0020,9072) are not sent. Enumerated Values: R = right L = left Note: Some IODs support Image Laterality (0020,0062) at the Image level or Frame Laterality(0020,9072) at the Frame level in the Frame Anatomy functional group macro, which can provide a more comprehensive mechanism for specifying the laterality of the body part(s) being examined.</p>	ALWAYS	AUTO
Module 'Clinical Trial Series'						
Information Entity 'Equipment'						
Module 'General Equipment'						
	(0008,0070)	LO	Manufacturer	"Carl Zeiss Meditec AG"	ALWAYS	AUTO
	(0008,0080)	LO	Institution Name	Institution where the equipment that produced the composite instances is located.	ALWAYS	CONFIG
	(0008,0081)	ST	Institution Address	Mailing address of the institution where the equipment that produced the composite instances is located.	ALWAYS	CONFIG
	(0008,1010)	SH	Station Name	User defined name identifying the machine that produced the composite instances.	ALWAYS	CONFIG
	(0008,1040)	LO	Institutional Department Name	Department in the institution where the equipment that produced the composite instances is located.	ALWAYS	CONFIG
	(0008,1090)	LO	Manufacturer's Model Name	Manufacturer's model name of the equipment that produced the composite instances.	VNAP	AUTO
	(0018,1000)	LO	Device Serial Number	Manufacturer's serial number of the equipment that produced the composite instances. Note: This identifier corresponds to the device that actually created the images, such as a CR plate reader or a CT console, and may not be sufficient to identify all of the equipment in the imaging chain, such as the generator or gantry or plate.	ALWAYS	AUTO

	(0018,1020)	LO	Software Versions	Manufacturer's designation of software version of the equipment that produced the composite instances.	ALWAYS	AUTO
	(0018,1050)	DS	Spatial Resolution	The inherent limiting resolution in mm of the acquisition equipment for high contrast objects for the data gathering and reconstruction technique chosen. If variable across the images of the series, the value at the image center.	VNAP	AUTO
Information Entity 'Image'						
Module 'General Image'						
	(0008,0008)	CS	Image Type	Overwrote by Module 'VL Image'		
	(0008,0022)	DA	Acquisition Date	The date the acquisition of data that resulted in this image started	VNAP	AUTO
	(0008,0023)	DA	Content Date	The date the image pixel data creation started. Required if image is part of a series in which the images are temporally related. Note: This Attribute was formerly known as Image Date.	VNAP	AUTO
	(0008,002A)	DT	Acquisition Datetime	The date and time that the acquisition of data that resulted in this image started. Note: The synchronization of this time with an external clock is specified in the Synchronization Module in Acquisition Time Synchronized (0018,1800).	VNAP	AUTO
	(0008,0032)	TM	Acquisition Time	The time the acquisition of data that resulted in this image started	VNAP	AUTO
	(0008,0033)	TM	Content Time	Overwrote by Module 'VL Image'		
	(0008,1140)	SQ	Referenced Image Sequence	Overwrote by Module 'VL Image'		
	>(0008,1150)	UI	Referenced SOP Class UID	Overwrote by Module 'VL Image'		
	>(0008,1155)	UI	Referenced SOP Instance UID	Overwrote by Module 'VL Image'		
	>(0008,1160)	IS	Referenced Frame Number	Overwrote by Module 'VL Image'		
	>(0040,A170)	SQ	Purpose of Reference Code Sequence	Overwrote by Module 'VL Image'		
	>>(0008,0100)	SH	Code Value	Overwrote by Module 'VL Image'		
	>>(0008,0102)	SH	Coding Scheme Designator	Overwrote by Module 'VL Image'		
	>>(0008,0103)	SH	Coding Scheme Version	Overwrote by Module 'VL Image'		
	>>(0008,0104)	LO	Code Meaning	Overwrote by Module 'VL Image'		
	>>(0008,0105)	CS	Mapping Resource	Overwrote by Module 'VL Image'		
	>>(0008,0106)	DT	Context Group Version	Overwrote by Module 'VL Image'		
	>>(0008,0107)	DT	Context Group Local Version	Overwrote by Module 'VL Image'		
	>>(0008,010B)	CS	Context Group	Overwrote by Module 'VL Image'		

	>>(0008,010D)	UI	Extension Flag Context Group Extension Creator UID	Overwrote by Module 'VL Image'		
	>>(0008,010F)	CS	Context Identifier	Overwrote by Module 'VL Image'		
	>(0062,000B)	US	Referenced Segment Number	Overwrote by Module 'VL Image'		
	(0008,2111)	ST	Derivation Description	A text description of how this image was derived. See C.7.6.1.1.3 for further explanation.	VNAP	AUTO
	(0020,0012)	IS	Acquisition Number	A number identifying the single continuous gathering of data over a period of time that resulted in this image.	VNAP	AUTO
	(0020,0013)	IS	Instance Number	Overwrote by Module 'VL Image'		
	(0020,4000)	LT	Image Comments	User-defined comments about the image	VNAP	USER
	(0028,0301)	CS	Burned In Annotation	"NO" <i>Indicates whether or not image contains sufficient burned in annotation to identify the patient and date the image was acquired. Enumerated Values: YES, NO If this Attribute is absent, then the image may or may not contain burned in annotation.</i>	ALWAYS	FIXED
	(0028,2110)	CS	Lossy Image Compression	Overwrote by Module 'VL Image'		
	(2050,0020)	CS	Presentation LUT Shape	"IDENTITY" – Exists if Photometric Interpretation (0028,0004) is "MONOCHROME2"	ANAP	AUTO
Module 'Image Pixel '						
	(7FE0,0010)	OW /OB	Pixel Data		ALWAYS	AUTO
Module 'Acquisition Context'						
	(0040,0555)	SQ	Acquisition Context Sequence	A sequence of Items that describes the conditions present during the acquisition of the data of the SOP Instance. Zero or more items may be included in this sequence.	ALWAYS	AUTO
	>(0040,08EA)	SQ	Measurement Units Code Sequence	Units of measurement. Only a single Item shall be permitted in this Sequence. Required if Numeric Value (0040,A30A) is sent. Shall not be present otherwise. Included macro 'Code Sequence Macro', context 'Baseline Context ID is 82. '	VNAP	AUTO
	>>(0008,0100)	SH	Code Value	See Section 8.1. Required if a sequence item is present.	VNAP	AUTO
	>>(0008,0102)	SH	Coding Scheme Designator	See Section 8.2. Required if a sequence item is present.	VNAP	AUTO
	>>(0008,0103)	SH	Coding Scheme Version	See Section 8.2. Required if a sequence item is present and the value of Coding Scheme Designator (0008,0102) is not	VNAP	AUTO

				sufficient to identify the Code Value (0008,0100) unambiguously.		
	>>(0008,0104)	LO	Code Meaning	See Section 8.3. Required if a sequence item is present.	VNAP	AUTO
	>(0040,A043)	SQ	Concept Name Code Sequence	A concept that constrains the meaning of (i.e. defines the role of) the Observation Value. The "Name" component of a Name/Value pair. This sequence shall contain exactly one item. Included macro 'Code Sequence Macro', context 'No Baseline Context is defined.'	VNAP	AUTO
	>>(0008,0100)	SH	Code Value	See Section 8.1. Required if a sequence item is present.	VNAP	AUTO
	>>(0008,0102)	SH	Coding Scheme Designator	See Section 8.2. Required if a sequence item is present.	VNAP	AUTO
	>>(0008,0103)	SH	Coding Scheme Version	See Section 8.2. Required if a sequence item is present and the value of Coding Scheme Designator (0008,0102) is not sufficient to identify the Code Value (0008,0100) unambiguously.	VNAP	AUTO
	>>(0008,0104)	LO	Code Meaning	See Section 8.3. Required if a sequence item is present.	VNAP	AUTO
	>(0040,A30A)	DS	Numeric Value	This is the Value component of a Name/Value pair when the Concept implied by Concept Name Code Sequence (0040,A043) is a set of one or more numeric values. Required if the value that Concept Name Code Sequence (0040,A043) requires (implies) is a set of one or more integers or real numbers. Shall not be present otherwise.	VNAP	AUTO
	(0040,0556)	ST	Acquisition Context Description	Free-text description of the image-acquisition context.	VNAP	AUTO
Module 'Device'						
Module 'VL Image'						
	(0008,0008)	CS	Image Type	4 items: 1. "ORIGINAL", "DERIVED" 2. "PRIMARY", "SECONDARY" 3. 4. "AF", "FA", "ICG", "COLOR", "RED", "BLUE", "GREEN", "MONTAGE"	ALWAYS	AUTO
	(0008,0033)	TM	Content Time		VNAP	AUTO
	>(0008,1150)	UI	Referenced SOP Class UID	Uniquely identifies the referenced SOP Class.	VNAP	AUTO
	>(0008,1155)	UI	Referenced SOP Instance UID	Uniquely identifies the referenced SOP Instance.	VNAP	AUTO
	(0028,0002)	US	Samples per Pixel	"1" for monochrome images. "3" for color images	ALWAYS	AUTO
	(0028,0004)	CS	Photometric Interpretation	"MONOCHROME2" for monochrome images, compressed or not compressed. "RGB" for color images not	ALWAYS	AUTO

				compressed. "YBR_422_FULL" for color images, compressed.		
	(0028,0006)	US	Planar Configuration	"0" for color images. Meaning is color-by-pixel	ANAP	AUTO
	(0028,0100)	US	Bits Allocated	"8"	ALWAYS	AUTO
	(0028,0101)	US	Bits Stored	"8"	ALWAYS	AUTO
	(0028,0102)	US	High Bit	"7"	ALWAYS	AUTO
	(0028,0103)	US	Pixel Representation	"0"	ALWAYS	AUTO
	(0028,2110)	CS	Lossy Image Compression	"00" - Image has NOT been subjected to lossy compression. "01" - Image has been subjected to lossy compression.	ALWAYS	AUTO
Module 'Overlay Plane'						
Module 'SOP Common'						
	(0008,0005)	CS	Specific Character Set	ISO_IR 100 Character Set that expands or replaces the Basic Graphic Set.	ALWAYS	AUTO
	(0008,0016)	UI	SOP Class UID	"1.2.840.1008.5.1.4.1.1.77.1.4"	ALWAYS	AUTO
	(0008,0018)	UI	SOP Instance UID	"1.2.276.0.75.2.1.20." as leading string when UID was created in the VISUCAM, by current software version.	ALWAYS	AUTO
	(0020,0013)	IS	Instance Number	A number that identifies this Composite object instance.	VNAP	AUTO

8.1.2 Usage of Attributes from Received IOD's

The usage of attributes of Modality Worklist IODs is described in chapter 4.2.1.3.1 Activity – Query Modality Worklist

8.1.3 Attribute Mapping

Modality Worklist	Instance IOD
Study Instance UID	Study Instance UID
Referenced Study Sequence	Referenced Study Sequence
Accession Number	Accession Number
Requested Procedure ID	Request Attributes Sequence > Requested Procedure ID
Scheduled Procedure Step Sequence > Scheduled Procedure Step ID	Request Attributes Sequence > Scheduled Procedure Step ID
Scheduled Procedure Step Sequence > Scheduled Procedure Step Description	Request Attributes Sequence > Scheduled Procedure Step Description
Scheduled Procedure Step Sequence > Schedule protocol Code Sequence	Request Attributes Sequence > Scheduled Protocol Code Sequence
Referring Physicians Name	Referring Physicians Name
Patients Name	Patients Name
Patient ID	Patient ID
Patients Birth Date	Patients Birth Date
Patients Sex	Patients Sex
Requesting Physician	Physician(s) of Record

8.1.4 Coerced/Modified Files

Those tags are listed in chapter 4.2.1.3.1 Activity – Query Modality Worklist. Other attributes get lost and are not available in the VISUCAM Application.

8.2 Data Dictionary of Private Attributes

8.3 Coded Terminology and Templates

8.3.1 Private Code Definitions

For exact information in fundus images, a few additional parameters, not defined in the VL-IOD, are used. These parameters are stored in a private Acquisition Context Sequence as defined below. The used Coding Scheme Designator is "99HIKO", the Coding Scheme Version is "VP4.0".

Hint: Relative angiography times (FA or ICG) have to be computed as difference between FA start time / ICG start time and Acquisition Datetime (0008, 002A)

Coding Name	Coding Type	Meas. Units Code / Values	Code Meaning / Comments
PixelWidth	Numeric Value with Unit	Millimeters	PixelWidth of used sensor
PixelHeight	Numeric Value with Unit	Millimeters	PixelHeight of used sensor
Sensor	Concept Code		Type of sensor
Angle	Numeric Value with Unit	Degrees	Viewing angle in degree
Flash	Numeric Value with Unit	Flash units	Flash level of the funduscamera
Sensor Gain	Numeric Value with Unit	Sensor Gain Unit	Total gain of the sensor funduscamera system
Gamma	Numeric Value with Unit	Gamma	Gamma value of the image
Focus aid	Numeric Value with Unit	none	Value 1 means: Focussing aid was ON
Focus position	Numeric Value with Unit	none	Position value of the focus
Eye section	Numeric Value with Unit	none	0: Anterior, 1: Posterior
Fixation Point	Numeric Value with Unit	none	Number of fixation point within a field method
Fixation point X	Numeric Value with Unit	none	X-Coordinate of the fix point
Fixation point Y	Numeric Value with Unit	none	Y-Coordinate of the fix point
Max fix points	Numeric Value with Unit	none	Maximum number of fixation point within a field method
FA start time	Time Code		Acquisition start time of FA series
ICG start time	Time Code		Acquisition start time of ICG series
Imaging agent	Concept Code		Contrast agent

8.4 Grayscale Image Consistency

Not applicable.

8.5 Standard Extended / Specialized/ Private SOP Classes

Specialized or Private SOP Classes are supported.

8.6 Private Transfer Syntaxes

No Private Transfer Syntaxes are supported.